

MTS

Product of the VOLLMER Group

tool-kit PROFESSIONAL by MTS – Product of the VOLLMER Group

Software-Modul Spezifikation „Punches/UMENU“

Stand: 15.01.25

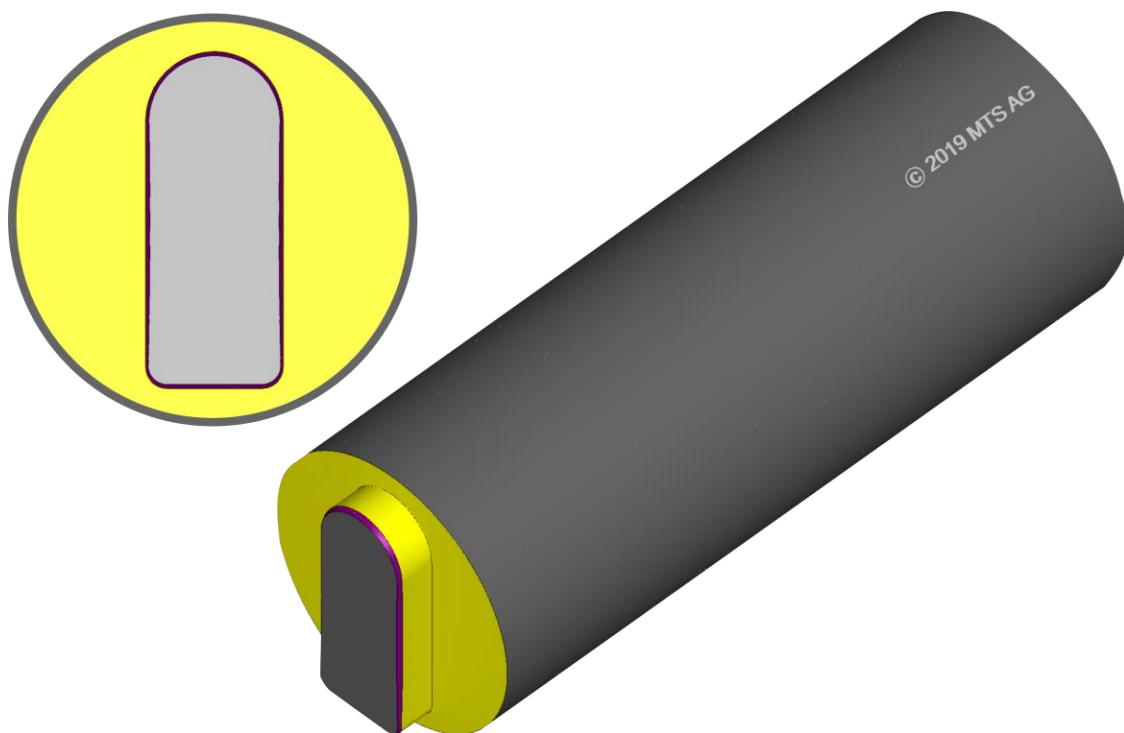

MTS – Product of the VOLLMER Group
Innovationszentrum Freiburg (FRIZ)
Georges-Köhler-Allee 302
79110 Freiburg im Breisgau
Tel.: +49 7351 571 8141 / +49 160 5426017
info@mtsag.net
www.mtsag.net

MTS

Product of the VOLLMER Group

14.Punches

UMENU

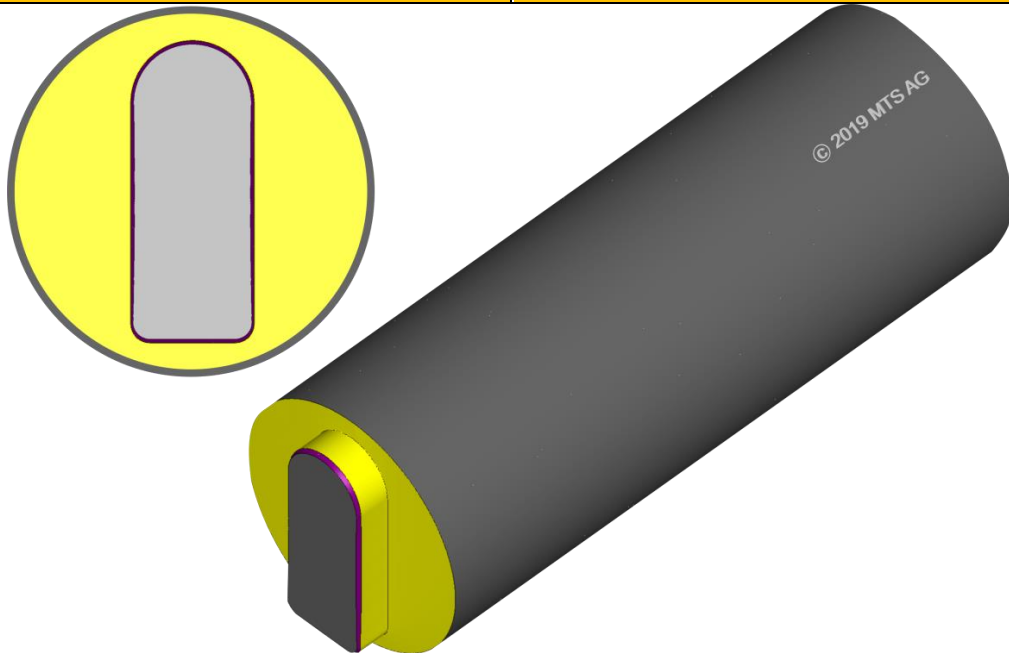

14.1 Basic Modul Punches

- **Workpiece:**
Circular grinding of any radial profile
Any axial profile (shank)
- **Profile:**
Standard profiles (integrated database)
Special profiles by integrated CAD-System for profile-construction
DXF-Import
Central/excentric profiles
- **Machining:**
Polygon-preparation
Profile roughing
Profile finishing
Profile polishing
- **Grinding Procedure:**
Deep grinding
Circular grinding (equal infeed)
Circular grinding (dynamical infeed)
Surface grinding.
- **Torx geometrie**